

Union Command Presents

# MAGIC ITEMS

A Supplement For No Quarter by Matt Lyon



The Fantasy Battles Miniatures Wargame

## Magic Items in Genayria

Genayria is swathed in magical energies and filled with creatures whose powers extend beyond the mundane. Small wonder then that there is high demand for the services of those who can manipulate these energies. Most magic users are content to use magic as a means to an end, creating fireballs from thin air, strengthening the weak, creating walls of air, etc. But these are all temporary uses quickly abandoned once the desired effect is achieved. A small percentage of magic users however are dedicated to making magic that lasts by imprinting it onto or into everyday items. Most are dismal failures, some few are successful but are never-the-less mundane (such as Master Thangorim's ever-burn candles). Those items of war which are imbued with magic are highly sought after and jealously guarded. As a result only the most powerful creatures and wealthiest nobles are likely to own even minimally magical items. Truly potent items are likely only to be found in the hands of mighty kings or the most ruthless warlords.

## Magic Item use in No Quarter

The magic items presented on the following pages are experimental and should only be used if both players agree to it. To use them, simply print out, cut and fold each card, then glue both halves together. For added strength, print onto cardstock or glue onto Bristol board before folding.

Magic Items are divided into the following types: Weapons, Armour, Shields, Items, Potions and Banners. Banners may only be purchased to replace the Army Banner, not individual unit banners.

Each player may have one set of magic items. While players may have the same magic items as their opponents, they may not have more than one of each magic item in their force (ie each player may have a model armed with The Jealous Blade but may not have more than one Jealous Blade within their own force).

Magic items are extremely rare and as such may only be carried by Individuals or Leaders. Named Characters may not be equipped with Magic Items. Each Individual or Leader may only be armed with one magic item regardless of cost unless players agree otherwise. In this case, models *may not* carry more than one magic item of each type (ie only one weapon card, only one armour card, etc).

Magic Items are purchased as part of the overall cost of the army. Alternatively, players may agree to a "magic items bonus", a set number of points to be spent over and above the total points value of the army. Players taking this option are recommended to limit this budget to 10-20% of the total army value (ie 200-400 points for magic items for a 2000 point army).

Most of the items listed function in a fairly straightforward manner and act immediately. Unless otherwise stated, players are not *required* to use magic items (ie items which dispel magic do not need to be employed against the first spell cast against that character unless the owning player so chooses). If needed, players may wish to employ markers or pointers of some sort to remind themselves about the status of certain items. Magic Items with a single use should be put to one side after being expended to avoid confusion.

On occasion, certain magic items may come into contact with other magic items which have an apparently contradictory or otherwise confusing effect. Players are reminded to use common sense whenever possible. Carefully re-read the card's description and consider the order of actions. If problems still arise, each player should declare their interpretation and roll a dice. The opinion of the player who scores lowest will be taken as granted in this instance and applied. If a similar problem arises in a future game, roll off as above but note down the point of contention and discuss it after the game. Create a house rule based on your conclusions for future use.

If you have any comments about the items presented here or suggestions for additional magic items, post your ideas on the No Quarter Message Board (<http://pub46.ezboard.com/fwargameschatfrm3>)





### **Sword of Fury**

This ancient blade has been used in over a hundred battles and is filled with the rage and bloodlust of war. A model equipped with the Sword of Fury may make one additional attack with no AC deduction.

**One Free Attack**  
**UC4 ST+1**

**10 Points**



### **Armour of Resistance**

Finely crafted armour designed to withstand far more punishment than one would expect. This armour functions exactly as normal with an AR4 but if the save is failed, a second roll may be made at AR3 but ignoring AM and PM modifiers.

**AR 4 and AR 3**  
**Unmodified**

**10 Points**



### **Sword of the Berserk**

Once drawn from its scabbard, the bearer of this weapon is slowly driven mad with bloodlust. A model carrying the Sword of the Berserk is assumed to automatically pass any CO test. Additionally, it **MUST** follow up if it is able to do so.

**Auto Pass CO tests**  
**MUST follow-up UC4ST+1**

**20 Points**



### **Helm of Volkan**

Forged in the depths of a volcano, this helm thirsts for flame! Any heat-based attacks (including magic spells, template attacks, weapons or explosives) against a model carrying this item are resolved at AR 8 unmodified.

**AR 4 (AR8 vs fire)**

**15 Points**



### Screaming Blade

This weapon resonates with the screams of those it has slain. A warrior armed with Screaming Blade causes fear[0] as described in the abilities section of the NO rulebook.

**UC 4 ST+1 Fear [0]**

**11 Points**



### Armour of Defiance

Finely crafted armour inscribed with runes of protection and endurance. This armour functions exactly as normal with an AR5 but if the save is failed, a second roll may be made at AR4 but ignoring AM and PM modifiers.

**AR 5 and  
AR 4 Unmodified**

**15 Points**



### Armour of Fortune

Thrice blessed by priests and anointed with sacred oils, the wearer of this armour is guarded by divine protection. A model equipped with this armour may re-roll a failed save, even on a natural 10. The second roll stands, even if it is worse.

**AR 5 +Re-roll**

**20 Points**



### Axe of Power

Used by the barbarian warlord Khonan, this weapon is designed for slaughter. Any target struck by this weapon will take 2 wounds damage and suffer a PM -2. A target with only one wound is slain and the second wound is wasted.

**UC 4 ST+1 PM -2  
2 wounds**

**20 Points**



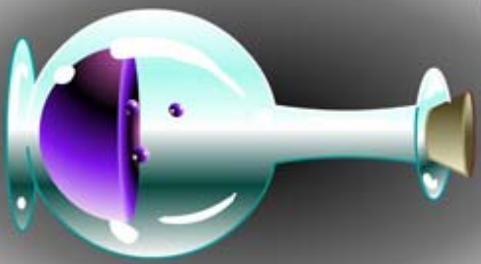

### Strength Potion

Brewed from foul mixture of potent roots and Ogre blood, this potion grants immense physical power to whoever drinks it. The potion may be drunk at a cost of IAC and confers a ST+3 (up to a maximum of 10) bonus until the model's next activation.

**UC 2 ST+3  
for one turn**

**10 Points**



### Shattered Arrow

A magical arrow made of glass. Once fired from it's bow, it shatters in mid-air and each shard becomes a new arrow. After nominating a target and checking range, roll D5x3 to determine the number of shards. Roll for each to hit as normal. Discard after use.

**D5x3 arrows ST 4 PM-1  
Use once then discard**

**15 Points**



### Threads of Fate

This magical twine is sewn into the clothes of it's owner on the eve of battle. They are tied into the fabric of the universe and as such allow their bearer limited control of his fate. Any failed saving throw may be re-rolled. The second roll stands.

**Re-roll any failed save**

**25 Points**



### Shield of Warding

Emblazoned with sigils of the four winds, this shield protects it's bearer from missile weapons (even cannons!). Against hand weapons the shield counts as AR +1 per normal. Against missile weapons, the model counts as AR 10. Normal modifiers apply.

**AR 10 vs missile weapons**

**15 Points**





### Mobius Amulet

Bestowing upon its bearer limited clairvoyance, the Mobius Amulet is a powerful charm. Once per game, a model wearing the amulet may re-roll a single failed dice roll and either add or subtract 1 from/to it.

**Re-roll +1/-1**

**15 Points**



### Sword of the Master

A remarkably light weapon that seems to move on its own when used in combat, actively deflecting otherwise lethal blows. The wielder of this sword may automatically parry one attack per combat round made against it, including weapons which hit automatically.

**UC 4 ST+1 Auto Parry**

**10 Points**



### Blade of Shatokk

A dagger who's hilt is shaped like a cobra, the Blade of Shatokk carries the crippling properties of its likeness. Any model wounded by this weapon will lose 2AC for the rest of the game. The effective is cumulative. A model reduced to 0AC is killed regardless of remaining wounds.

**UC3 PM-1 AC-2**

**20 Points**

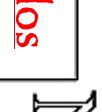

### Ring of Talos

This deceptively plain ring is a potent defense against magic. Any spell cast against the wearer of this ring (and any unit he is with) will be cancelled on a D10 score of 4 or less. This will only work once per game turn however, so a second or subsequent spell will effect the wearer as normal.

**Cancel magic on 1-4**

**15 Points**

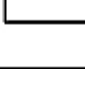
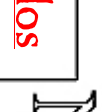



### Sacred Blade

The Sacred Blade was forged to drive back the Living Dead. Any Living Dead model hit by this weapon receives 2 wounds automatically. No save is granted even for ethereal creatures. Against live opponents, the sword has no special powers.

**UC 4 ST+1 2 wounds**  
*no save vs. Living Dead*

**30 Points**



### Armour of the Sun

Golden armour polished to an unmatched level of brilliance. A warrior equipped with this armour is hard to fight, owing to the blinding reflections it makes. Any model fighting the wearer of the Armour of the Sun suffers a CC-2 penalty for the duration of the combat.

**AR 5 Enemy CC-2**

**20 Points**



### Vampyre Blade

Like the beast for which it is named, this weapon drains the very life from its victims. Any model wounded by the Vampyre Blade will also suffer ST-1 for the rest of the game. The effect is cumulative. A model reduced to ST 0 is killed regardless of remaining wounds.

**UC4 ST+1 Victims**

**20 Points**



### Banishment Scroll

Inscribed in the ancient language of Mal'ek, the Banishment Scroll is one of the best magic defenses. Only a magic using model may carry this item. It will automatically nullify any spell cast against it or any unit it accompanies. It may alternatively be used cancel any template effect spell within LOS. One use only.

**Automatic dispel One use only**  
*Magic Users Only*

**30 Points**



### Sceptre of Power

This magic rod was imbued with great energies in times long past. One acquainted with the ways of magic can exploit them. A magic using model equipped with the Sceptre of Power may cast one spell per activation with no difficulty test required. UC cost per spell as normal

Auto Spell casting UC cost as normal Magic Users only

30 Points



### Circlet of Mesmos

This silver band features a large opal in its centre. Anyone who looks directly at it will become mesmerized. A model wishing to attack the wearer of the Circlet of Mesmos must pass a CO test otherwise they will become transfixed. Any blows struck against transfixed enemies will hit automatically. The target makes a new test each time it is activated to see if it can break the spell. If it passes, the circlet no longer has any effect on it.

20 Points



### Arctic Blade

Forged over magically cold fires, the Arctic Blade chills the blood of those it cuts. Any model wounded by the Arctic Blade will also suffer T-1 for the rest of the game. The effect is cumulative. A model reduced to T 0 is killed regardless of wounds remaining.

UC4 ST+1 Victim's T-1 if wounded

20 Points



### Crown of Khane

Khane was a warrior king who swore he would strike back at those who slew him. His crown was thus filled with his need for vengeance. If a model wearing the Crown of Khane is killed, the jewels on the crown will shatter. Place a 2" template centered over the casualty. Any model under the template will be hit at ST5 PM-1.

2" blast ST5 PM-1 upon death of wearer

10 Points



### Blade of Fools

A weapon that steals the very wits from it's victims as surely as it draws their blood. Any model wounded (but not killed) by the Blade of Fools will become **CONFUSED** as described in the traits section of the NQ rulebook on a D10 roll of 8+.

**UC 4 ST+1 Victim becomes CONFUSED**

**30 Points**



### Scroll of Destruction

The Scroll of Destruction is deadly to magic users. Only a magic using model may carry this item. It will automatically nullify any spell cast against it or any unit it accompanies. It may alternatively be used cancel any template effect spell within LOS. Additionally, the caster of the defeated spell must take a CO test. If they fail, that spell is erased from their mind and cannot be cast again this game.

**Magic User Only  
One Use Only**

**50 Points**



### Axe of Cruelty

The Axe of Cruelty seems to pulsate with malice. Any hits scored in combat with this weapon count as two hits and two rolls to wound are made separately. If the first wound kills the opponent, the second hit is wasted.

**UC4 ST+1 PM -1  
hits x2**

**15 Points**



### Blade of Deception

Forged of irons drawn from a meteorite, the uncanny sharpness of this weapon is beyond belief. Any model struck by this weapon receives no saving throw. If the target wears magical armour, it receives the base saving throw but discounts any non-magical elements (such as shields and harding).

**UC4 ST+1 No save vs.  
Non-magic Armour**

**20 Points**





### **The Serpent's Tongue**

A curved dagger that strikes like lightning, the Serpent's Tongue is almost impossible to defend against. Any model armed with the Serpent's Tongue hits automatically in combat, no roll to hit is necessary, simply proceed to wound rolls and saving throws (if applicable).

**UC 3 PM-1**

**Hits Automatically**

**30 Points**

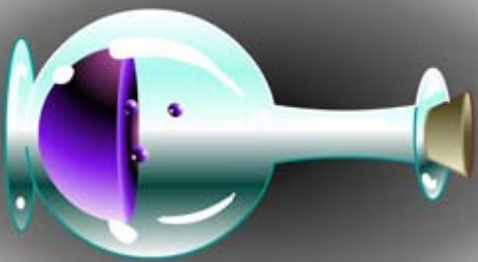

### **Nectar of Life**

This pungent broth is empowered with the very spark of life itself. A model carrying the Nectar of Life may drink from it at any time except when engaged in combat. Once drunk, this potion restores all wounds to the model (up to their original maximum).

**UC 2 Restores Lost**

**wounds Use once, then discard**

**30 Points**



### **Blade of Ahkla**

Ahkla was a deadly assassin. His expertise at dispatching opponents was magically transferred to his trusty dagger upon his death. A model armed with the Blade of Ahkla may re-roll any missed attacks once. The second roll stands.

**UC 3 PM-1**

**re-roll misses**

**20 Points**



### **Nightmare Blade**

This weapon resonates with the screams of those it has slain and ghostly faces reflect in its blade. A warrior armed with the Nightmare Blade causes fear[2] as well as gaining the Unwavering ability as described in the abilities section of the NO rulebook

**UC 4 ST+1 Fear [2]**

**becomes Unwavering**

**30 Points**



NO

QNT

### Amulet of Resurrection

Intoned with dark sorcery, this amulet grants limited immortality to it's wearer. If a model wearing the amulet is reduced to 0 wounds, it is not killed but is immediately moved back to it's table edge and restored to full wounds. The Amulet of Resurrection only works once per game.

**Restores All Wounds**  
**Use then Discard**

**30 Points**

QNT



NO

QNT

### Scimitar of the Liche

Crushed bones were used in the forging of this foul weapon. Only a Living Dead character may carry this weapon. Any model with 1 wound that is killed by this weapon is automatically turned into a Skeleton (see Living Dead Army List). It may be joined to an existing unit or form a new unit around the holder of the Scimitar.

**UC 4 ST+1**  
**victim becomes Skeleton**

**45 Points**

QNT



NO

QNT

### Shield of Reflection

Polished with quicksilver, this shield has a mirror-like finish that confounds magic. Against hand weapons the shield counts as AR+1 per normal. Against magic attacks the shield will nullify the spell on a roll of 5 or less. Against template-using magic, the spell is not cancelled but is automatically deflected 2D10" in a random direction.

**30 Points**

QNT



NO

QNT

### Codex of Ur

This weighty tome resonates with otherworldly energies and contains almost everything known of magic in Genayria. The carrier of the Codex may cast one additional spell per turn from ANY spell group (UC as normal). However, before attempting to cast, a test must be made. On a roll of 9 or 10, the book vanishes and the model takes one wound automatically with no save.

**Magic Users Only**

**40 Points**

QNT

NO

NO



### The Crystal Skull

A mysterious object of unknown origin, the Crystal Skull shimmers with ghostly light. A magic user carrying the Crystal Skull may attempt to cast one spell per activation for 0UC and at difficulty +2 (to a maximum of 9). Each time the Crystal Skull is used roll a D10. On a roll of 9 or 10 it is exhausted and crumbles to dust.

**Magic Users Only**

**30 Points**



### The Jealous Blade

Narcissism incarnate, this sword cannot tolerate the presence of other magic items. If a model armed with the Jealous Blade is in combat with another model carrying a magic item, the enemy model must pass a test each time it takes a wound. On a D10 score of 1-3 the enemy model's magic item is destroyed.

**UC 4 ST+1 Destroys Magic Items on roll of 1-3**

**50 Points**



### Blade of Fangs

Heavily serrated and dipped in a poison that never runs dry, the Blade of Fangs is one of the deadliest weapons ever forged. Any model sustaining a wound from the Blade of Fangs that fails it's saving throw receives D5 wounds. All wounds are directed against a single target, so if the target is killed the excess wounds are wasted.

**UC 4 ST+1 inflicts D5 wounds**

**50 Points**



### Sword of the Hydra

This weapon seems to thrash about with a life of it's own and only the most skilled warrior can wield it. If a model armed with this weapon scores a hit in combat it becomes D5 hits. Roll to wound for each separately. Any CC bonuses or penalties apply. All extra hits must be directed against a single enemy. If it is killed, excess hits are lost.

**UC 4 ST+1 D5 hits**

**50 Points**



### Obsidian Talisman

Made of highly polished volcanic glass, the Obsidian Talisman protects it's carrier for all manner of harm. Any attacks made against this model will suffer a penalty (CC-1 for close combat, RA-1 for missiles). Additionally, any magic spell cast against the holder of this item will be nullified on a roll of 1-3

CC-1/RA-1 Dispel on 1-3

50 Points



### The Reaper

This weapon is death incarnate. Few may even touch it without being horribly crippled or even killed. Those few the Reaper permits to carry it are virtually unstoppable. Any model wounded by the Reaper is killed automatically, regardless of number of wounds. Normal saving throws apply. Magic armour only counts it's AR value against this weapon.

Auto Kills

75 Points

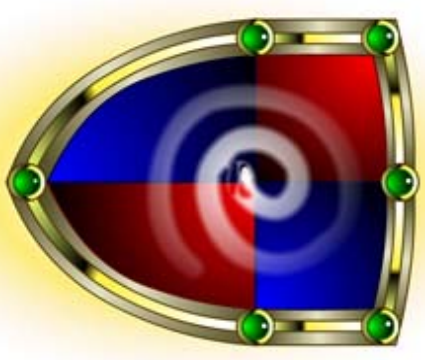

### Spell Swallower

To the ordinary eye, this shield is blank. To the eyes of a magic user, this shield is a vicious maw, constantly hungry. In combat, this shield confers the usual AR+1. Any magic cast against a model armed with the Spell Swallower will be automatically dispelled. Additionally, the enemy magic user must pass a CO test. If he fails, the spell is erased from his mind and may not be cast again for the remainder of the game

Auto Dispel Spell destroyed if CO test failed

50 Points



### Thieving Blade

This weapon feeds on other magic weapons as a Vampire does the living. Any model carrying a magic weapon that is in combat with a model armed with this weapon and is wounded must take a test. On a score of 1-3 it becomes a normal weapon of it's type. The model carrying the Thieving Blade may now use that weapon's power. Only one test is made per combat. Weapons whose powers cannot be used by the model carrying the Thieving Blade are still rendered inert. If the model enters another combat with a magic weapon bearing model, the first power is lost and replaced by the newly leached power.

UC 4 ST+1 Leeches Magic

80 Points





### **Sword of the Slayer**

The weapon of heroes of legend, this sword has slain demons, dragons and all manner of unspeakable horrors. If a model armed with the Sword of the Slayer is attacking a LARGE (or VERY LARGE) target, the model gains an additional ST+2 and causes D5 wounds with PM-2. The model also becomes Unwavering as described in the NO rulebook.

**UC 4 ST+1 (ST+3 PM-2)  
D5 wounds vs Large Targets)**

**75 Points**

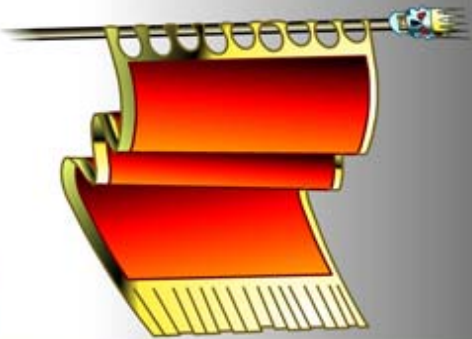

### **Banner of Slaughter**

This banner radiates savagery. Any model or unit engaged in combat with a unit carrying the Banner of Slaughter will suffer an additional D5 wounds automatically. The wounds are distributed randomly throughout the targeted unit. No save is permitted for normal armour but magic armour works as usual.

**Additional D5 wounds in  
combat with no saves**

**100 Points**



### **Hammer of Justice**

Imbued with furious retribution, the Hammer of Justice smites all who oppose it's wielder. Any model hit by the Hammer of Justice is wounded automatically. Normal Saving throws do not apply and magical armour is counted for it's AR value only, any additional magical properties are discounted.

**UC 4 ST+1 Auto Wounds  
No Saves for  
Non-magical armour**

**75 Points**



### **Malakia's Pendant**

This magical jewel holds tremendous energies within itself. Before the game begins, a model carrying Malakia's Pendant takes one spell card at random from any magic deck available to that army. The spell within Malakia's Pendant may be cast at any time for OAC and no difficulty test is required. Once cast the Pendant is drained, discard this item and the spell card.

**Auto Cast one Random Spell**

**50 Points**



## Scroll of Odun

The silvery ink inscribing this scroll is almost impossible to read for all but the magically inclined. Once per game, the carrier of the Scroll of Odun may read it, unleashing a Lightning Bolt spell (see Light Magic in the NQ rulebook). The spell is cast automatically and needs no difficulty test. Magic Users only. Discard after use.

**Auto Cast Lightning Bolt**  
**One use Only**  
**Magic Users Only**

**50 Points**

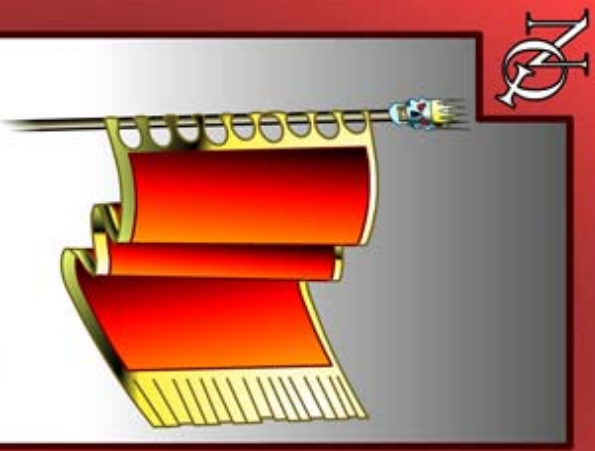

## Banner of Fortitude

A unit carrying this standard is filled with a sense of duty and martial pride. They would rather die than flee the field in disgrace. Any unit bearing the Banner of Fortitude becomes Unwavering as described in the abilities section of the NQ rulebook.

**Unit Becomes Unwavering**

**100 Points**

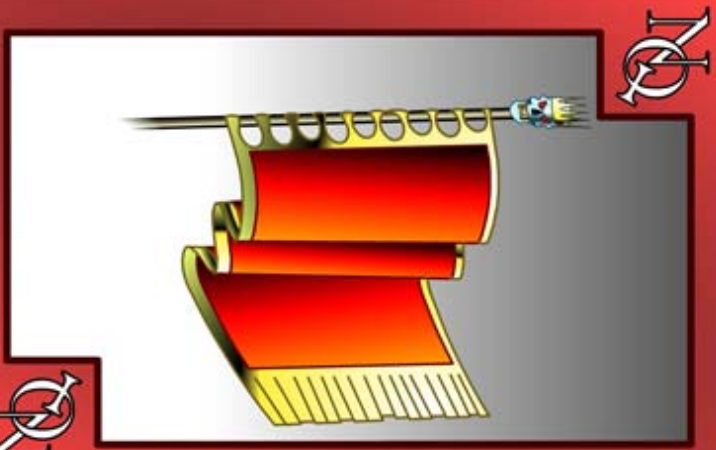

## Dragon Standard

This totem is shaped in the likeness of a mighty dragon. When a unit carrying this standard is activated it may cast a FIREBALL, with the effects and properties of the spell listed in the Fire Aspect in the Magic section of the NQ rulebook. The spell costs UC0 and requires no difficulty test.

**Auto Cast FIREBALL**  
**when activated**

**75 Points**

## Wand of Storms

The Wand of Storms can command the very heavens themselves, causing great winds to howl, and hail to fall from skies that were clear but moments before. When activated, the Wand of Storms prevents ALL models with the FLYING trait from doing so and they are limited to ground movement only until the model carrying the wand is slain or until that model's next activation.

**UC 6 Denies FLYING**

**75 Points**